

GATHER AROUND



BROWN JORDAN
FIRES

The simplest things often inspire our most memorable moments. The radiating glow of a distant fire, the warmth of a flame or the familiar laugh of a friend - these are the details that make us pause and the fleeting moments that inspire us to *Gather Around*.

Our collection of innovative outdoor fires offer the ultimate in freedom and flexibility. Choose a style that fits your outdoor setting, a size that makes the most sense, a finish that complements your furniture and a fuel source that best suits your needs. Whether you're seeking a firepit, fire table or decorative accent, you'll find a range of sizes, colors, shapes and finishes to choose from as you select the perfect fire feature to complete your outdoor space.

FIREPITS 05



URTH

FIRE TABLES 15



KOVE



SOLSTICE



FLO



EQUINOX

ACCESSORIES 31



HIDEOUT



PIVOT
(STOOL OR SIDE TABLE)

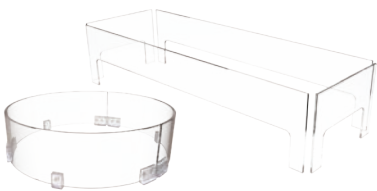

SCREENS

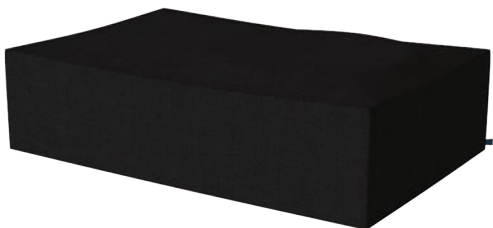

COVERS*
*Included with outdoor models only.

COLLECTION



Our firepits bring a streamlined and modern aesthetic to the traditional outdoor fire. Made from durable, yet lightweight Fluid Concrete Technology, our firepits are available in a range of shapes, sizes, fuel types and finishes that fit in and enhance any outdoor space. As a staple of outdoor living, you're guaranteed to make memories around your firepit for years to come.

FIREPITS



Urth's elegant form and vibrant flame provide a warm and inviting centerpiece to gather around and relax in front of, no matter the season. Urth's eco-friendly ethanol fuel offers a beautiful bright orange flame and its smooth natural, graphite or bone color concrete finish easily pairs with any outdoor furniture.

L 34" (850)

W 34" (850)

H 16" (407)





URTH - NATURAL





Elegant in their simplicity, our fire tables are functional designs with ample space to set down food or drinks when entertaining guests. More than accents, our streamlined fire tables provide a welcoming destination and gathering spot. Each model in the collection can serve as a standalone feature or be used in tandem with other fire tables for larger configurations. Offered in a natural, raw concrete finish and round or linear flame patterns, our collection of fire tables are versatile enough for any outdoor space.

FIRE TABLES



KOVE - BONE

A fusion of modern and classic design elements, Kove is the perfect complement to any curved or circular furniture setting. Its round shape and soft lines are naturally inviting for friends and family to gather around and share its warmth. Standing over 13 inches (339mm) tall, with a substantial 44 inch (1117mm) diameter, Kove features a functional ledge for accommodating food and drinkware. Pair Pivot stools to complete any alfresco space.

L 44" (1117)
W 44" (1117)
H 13" (339)





EQUINOX - NATURAL



EQUINOX - NATURAL



Spacious table and fire feature in one, Equinox is well styled and perfectly suited for entertaining. Its modular design allows it to be paired with Solstice for a custom configuration that can accommodate even your largest happenings. With its unique sunken burner design and subtle transition from fire to table, entertaining large groups just got easier.

L 65" (1650)

W 39" (1000)

H 13" (339)





EQUINOX - NATURAL





SOLSTICE - NATURAL

Solstice combines the warmth of a glowing fire with the convenience of a functional tabletop in a compact form. At 40" (1000mm) square, Solstice can accommodate drinkware and provides a beautiful focal point for any outdoor space. Modular in design, Solstice can be combined with Equinox to create a larger feature or design concept. The flexibility that Solstice provides is an especially welcomed feature in hospitality or restaurant settings - be creative and configure to suit your needs.

L 40" (1000)
W 40" (1000)
H 13" (339)





SOLSTICE - BONE

Photo: Michele Lee Willson
Designer: SVK Interior Design



SOLSTICE - NATURAL



FLO - BONE



FLO* - NATURAL

*Location image are indicative only



Handcrafted to ensure a smooth and consistent finish, Flo's high-performance concrete tabletop is complemented by a 36" (914mm) linear flame nestled at its center. Flo's generous dimensions leave plenty of room for servingware and its linear design makes it a stunning conversation piece. Available in your choice of fuel type - bioethanol, natural gas or propane - Flo's accommodating proportions give you the space and freedom to entertain your way.

L 65" (1650)

W 39" (1000)

H 13" (339)



GLASS SCREEN
ACCESSORY

FLO



FLO - NATURAL



FLO - GRAPHITE



HIDEOUT AND EQUINOX - NATURAL

*Location image are indicative only

Put the finishing touch on your fire design with accessories designed to enhance the Brown Jordan Fires experience for you and your guests. Our already vibrant flame becomes even more robust when framed by our tempered glass fire screens. With our versatile stools and side tables, you'll never run out of extra seating or space.

ACCESSORIES

HIDEOUT

TANK COVER, STOOL OR SIDE TABLE

Made from our unique, hand-finished concrete, Hideout is a clean-lined accessory designed to house a propane tank. Available in a smooth, natural, graphite or bone finish, hideout effortlessly matches the entire Brown Jordan Fires collection and also doubles as a convenient stool or side table.

L 18" (450)

W 18" (450)

H 21" (525)



PIVOT

STOOL OR SIDE TABLE

Stylish and edgy by design, Pivot is versatile, doubling as a stand-alone side table, or trendy stool. Pivot is light enough for easy mobility but heavy enough for commercial use on a pool deck, balcony, or other amenity space. Pivot seamlessly integrates with any fire in our collection. The height-adjustable, articulating feet feature, allows for stability on nearly any surface. Pivot is available in natural, graphite or bone finishes.

L 15" (390)

W 15" (390)

H 18" (466)



GLASS SCREENS

Available in a variety of shapes and sizes our fire screens are an optional accessory that complements the aesthetic of our collection of fires. Made of tempered glass they feature polycarbonate connectors and serve to stabilize the flame in windy conditions and can be an added layer of safety and comfort.



COVERS*

Take care and protect your investment by using our high quality protective outdoor covers when your fireplace is not in use. Made from stain resistant, water proof material these custom covers are an essential accessory.

*Included with outdoor models only.

Smart design is in the details.
That's why each element of your
Brown Jordan Fire has been carefully
designed and tested to ensure
high performance all year long.
From burner efficiency to concrete
durability, no detail has been
overlooked. We aspire to provide
you with an outdoor fireplace that
will not only beautifully accent your
space but will continue to do so for
years to come.

DETAILS



BROWN JORDAN

DIMENSIONS

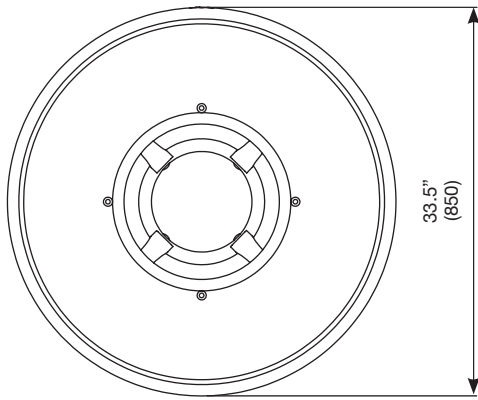

Top View

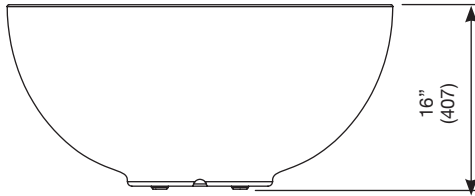

Front View

Urth’s sunken flame sits below the lip of the firebowl and is cradled by a built-in shelf which also serves to support the included glass charcoal. At 33.5” (850mm) in diameter, Urth is light enough to be easily repositioned as needed. For ultimate flexibility, residential and commercial users alike gravitate towards this bioethanol fire pit because there is no need for hard utility connections, this makes it incredibly simple to relocate as needed.

MATERIALS

Fluid Concrete Technology* surround, Grade 304 Stainless Steel Burner and glass charcoal.

*Concrete is a natural material. Each piece is hand made. Pieces are similar, but no two pieces are identical in color or appearance.

MODEL OPTIONS

Fuel	Color	SKU
Bioethanol	Natural	BJF.2.UTH.NA.E
	Graphite	BJF.2.UTH.GH.E
	Bone	BJF.2.UTH.BO.E

HEAT OUTPUT*

Fuel	BTU/Hr	Burn Hours
Bioethanol	20,000	7 - 11

*These values are indicative only. Bioethanol Burner is UL Listed.

INCLUDED ACCESSORY

Accessory	SKU
Outdoor Cover	BJF.5.WB.UTH

OPTIONAL ACCESSORIES

Accessory	SKU
Hideout (Tank Cover or Side Table)	BJF.2.HDT
Pivot (Stool or Side Table)	BJF.2.S.PVT

URTH



BROWN JORDAN

DIMENSIONS

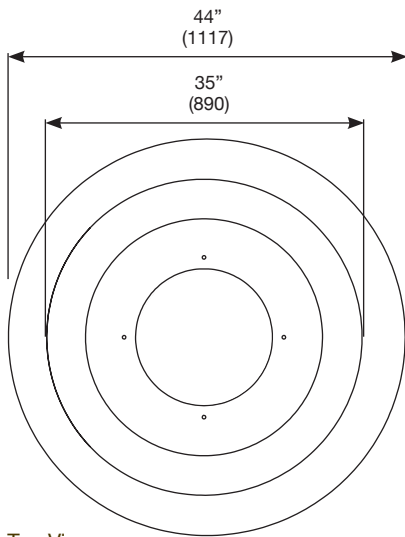

Top View

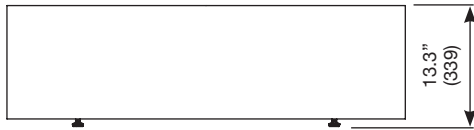

Front View



Constructed from proprietary Fluid Concrete Technology, Kove is durable, lightweight and built to perform. Standing 13" (330mm) tall with a substantial 44" (1117mm) diameter, Kove features a functional ledge for accommodating food and drinkware. Kove's articulating feet allow for easy mobility and perfect leveling. The optional glass screen is effortlessly integrated for a seamless, polished look and added functionality.

MATERIALS

Fluid Concrete Technology* surround, Grade 304 Stainless Steel Burner and glass charcoal.

*Concrete is a natural material. Each piece is hand made. Pieces are similar, but no two pieces are identical in color or appearance.

MODEL OPTIONS

Fuel	Color	SKU
LP/NG	Natural	BJF.5.KOV.NA.G
	Graphite	BJF.5.KOV.GH.G
	Bone	BJF.5.KOV.BO.G
Bioethanol	Natural	BJF.5.KOV.NA.E
	Graphite	BJF.5.KOV.GH.E
	Bone	BJF.5.KOV.BO.E

HEAT OUTPUT*

Fuel	BTU/Hr	Burn Hours
LP	65,000	8 - 20
NG	65,000	Unlimited
Bioethanol	20,000	7 - 11

*These values are indicative only.
LP/NG Burners are UL/ULC Listed.
Bioethanol Burner is UL Listed.

INCLUDED ACCESSORY

Accessory	SKU
Outdoor Cover	BJF.5.WB.KOV

OPTIONAL ACCESSORIES

Accessory	SKU
Glass Screen	BLD.1.A.G.R650
Hideout (Tank Cover or Side Table)	BJF.2.HDT
Pivot (Stool or Side Table)	BJF.2.S.PVT





DIMENSIONS

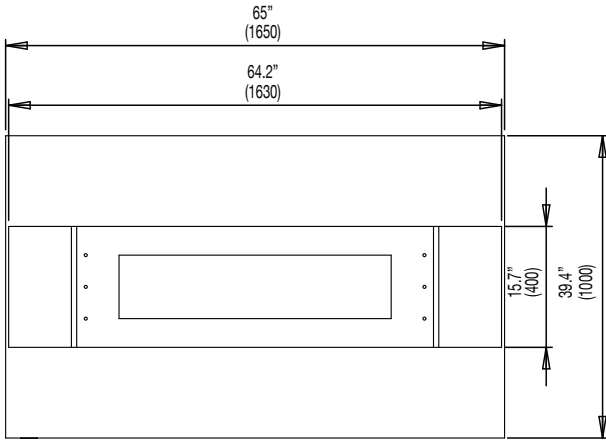

Top View

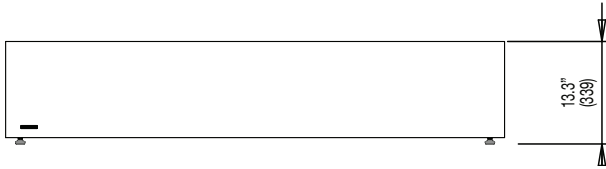

Front View



Flo's molded unibody construction provides a seamless and durable surface that withstands regular use and outdoor elements. Fueled by your choice of bioethanol, natural gas or propane, Flo gives you the freedom to choose the fuel type that makes the most sense for your space. Flo features four height adjustable articulating feet that ensure your table remains balanced on all different types of outdoor surfaces.

MATERIALS

Fluid Concrete Technology* surround, Grade 304 Stainless Steel Burner and glass charcoal.

*Concrete is a natural material. Each piece is hand made. Pieces are similar, but no two pieces are identical in color or appearance.

MODEL OPTIONS

Fuel	Color	SKU
LP/NG	Natural	BJF.5.FLO.NA.G
	Graphite	BJF.5.FLO.GH.G
	Bone	BJF.5.FLO.BO.G
Bioethanol	Natural	BJF.5.FLO.NA.E
	Graphite	BJF.5.FLO.GH.E
	Bone	BJF.5.FLO.BO.E

HEAT OUTPUT*

Fuel	BTU/Hr	Burn Hours
LP	65,000	8 - 20
NG	65,000	Unlimited
Bioethanol	15,000	8 - 13

*These values are indicative only.
LP/NG Burners are UL/ULC Listed.
Bioethanol Burner is UL Listed.

INCLUDED ACCESSORY

Accessory	SKU
Outdoor Cover	BJF.5.WB.EQU.FLO

OPTIONAL ACCESSORIES

Accessory	SKU
Glass Screen	ESF.5.A.G.L1080
Hideout (Tank Cover or Side Table)	BJF.2.HDT
Pivot (Stool or Side Table)	BJF.2.S.PVT





DIMENSIONS

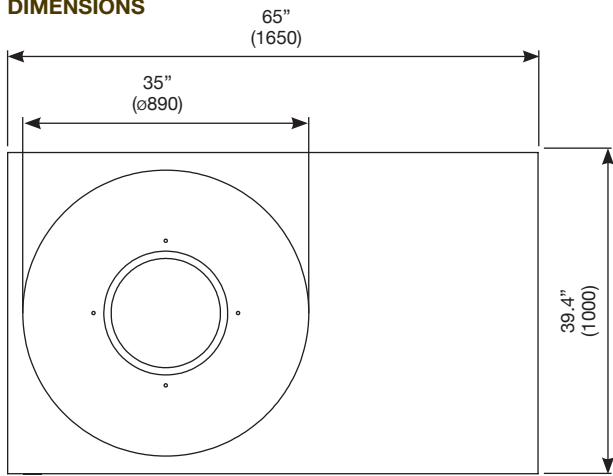

Top View



Front View

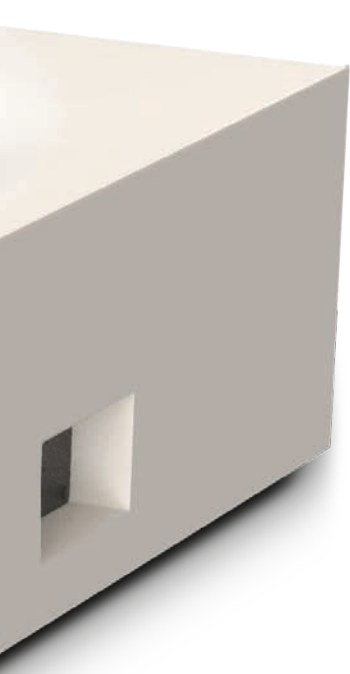

Equinox is made from an easy to maintain Fluid Concrete Technology that is light enough to allow for flexibility yet durable enough for long-term use in residential and commercial settings alike. Available in a natural concrete finish with your choice of burner system (bioethanol, natural gas or propane), Equinox is 65" (1650mm) long and can be extended to any length by using its modular counterpart - Solstice.

MATERIALS

Fluid Concrete Technology* surround, Grade 304 Stainless Steel Burner and glass charcoal.

*Concrete is a natural material. Each piece is hand made. Pieces are similar, but no two pieces are identical in color or appearance.

MODEL OPTIONS

Fuel	Color	SKU
LP/NG	Natural	BJF.5.EQU.NA.G
	Graphite	BJF.5.EQU.GH.G
	Bone	BJF.5.EQU.BO.G
Bioethanol	Natural	BJF.5.EQU.NA.E
	Graphite	BJF.5.EQU.GH.E
	Bone	BJF.5.EQU.BO.E

HEAT OUTPUT*

Fuel	BTU/Hr	Burn Hours
LP	65,000	8 - 20
NG	65,000	Unlimited
Bioethanol	20,000	7 - 11

*These values are indicative only. LP/NG Burners are UL/ULC Listed. Bioethanol Burner is UL Listed.

INCLUDED ACCESSORY

Accessory	SKU
Outdoor Cover	BJF.5.WB.EQU.FLO

OPTIONAL ACCESSORIES

Accessory	SKU
Glass Screen	BLD.1.A.G.R650
Hideout (Tank Cover or Side Table)	BJF.2.HDT
Pivot (Stool or Side Table)	BJF.2.S.PVT





DIMENSIONS

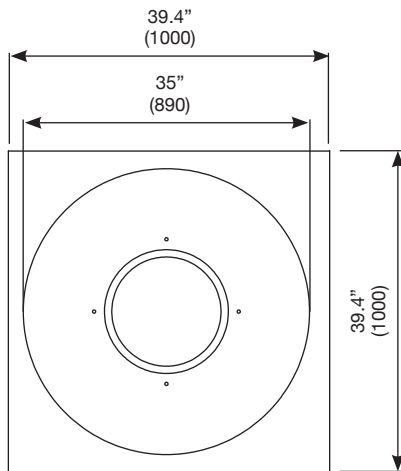

Top View



Front View



At 40" (1000mm) square and 13.3" (339mm) high, Solstice is a fire table that works on its own as a focal point and gathering spot or as part of a larger design. Solstice offers the freedom of choice when it comes to fuel type - select a bioethanol, natural gas or propane burner based on your needs. The natural Fluid Concrete Technology possesses the strength of traditional concrete at a fraction of the weight. Add the optional round protective glass for increased safety or pair with matching Pivot stools to be used as seating or side tables.

MATERIALS

Fluid Concrete Technology* surround, Grade 304 Stainless Steel Burner and glass charcoal.

*Concrete is a natural material. Each piece is hand made. Pieces are similar, but no two pieces are identical in color or appearance.

MODEL OPTIONS

Fuel	Color	SKU
LP/NG	Natural	BJF.5.SOL.NA.G
	Graphite	BJF.5.SOL.GH.G
	Bone	BJF.5.SOL.BO.G
Bioethanol	Natural	BJF.5.SOL.NA.E
	Graphite	BJF.5.SOL.GH.E
	Bone	BJF.5.SOL.BO.E

HEAT OUTPUT*

Fuel	BTU/Hr	Burn Hours
LP	65,000	8 - 20
NG	65,000	Unlimited
Bioethanol	20,000	7 - 11

*These values are indicative only.
LP/NG Burners are UL/ULC Listed.
Bioethanol Burner is UL Listed.

INCLUDED ACCESSORY

Accessory	SKU
Outdoor Cover	BJF.5.WB.SOL

OPTIONAL ACCESSORIES

Accessory	SKU
Glass Screen	BLD.1.A.G.R650
Hideout (Tank Cover or Side Table)	BJF.2.HDT
Pivot (Stool or Side Table)	BJF.2.S.PVT

SOLISTOLES



DIMENSIONS

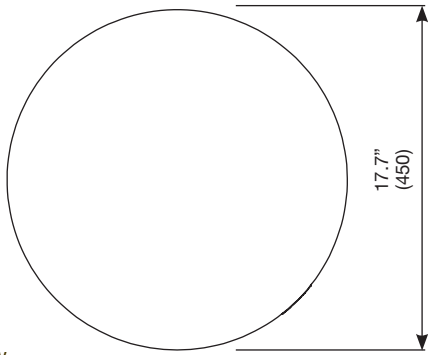

Top View

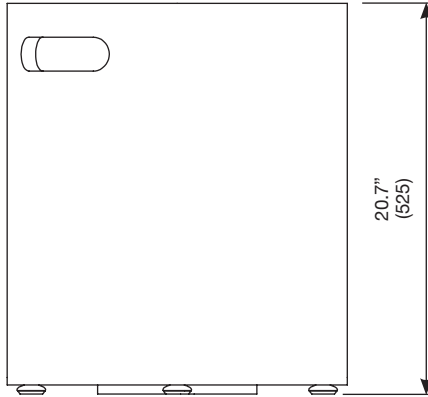

Front View

Hideout is perfectly sized to discreetly hide a propane tank while also doubling as a functional and impactful side table or stool. Its natural, graphite or bone finish makes for discreet integration into surrounding decor while its light-weight and built-in handles make for easy relocation.

MATERIALS

Fluid Concrete Technology* surround.

*Concrete is a natural material. Each piece is hand made. Pieces are similar, but no two pieces are identical in color or appearance.

MODEL OPTIONS

Color	SKU
Natural	BJF.2.HDT.NA
Graphite	BJF.2.HDT.GH
Bone	BJF.2.HDT.BO

COMPATIBLE MODELS

Model	SKU
Equinox	BJF.5.EQU
Flo	BJF.5.FLO
Kove	BJF.5.KOV
Solstice	BJF.5.SOL
Urth	BJF.2.UTH

OPTIONAL ACCESSORIES

Accessory	SKU
Outdoor Cover	BJF.1.C.HDT

HIDEOUT



DIMENSIONS

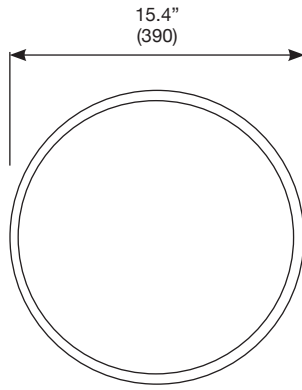

Top View

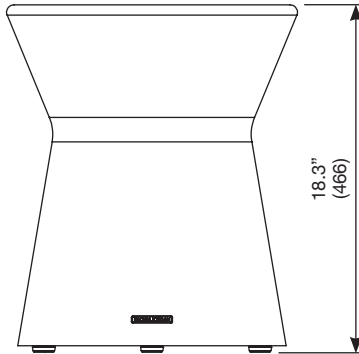

Front View

Pivot is versatile, doubling as either a stand-alone side table or trendy stool. Pivot seamlessly integrates with any fire in our collection. Manufactured from a proprietary Fluid Concrete Technology, Pivot is light for easy mobility, but heavy enough for commercial use on a pool deck, balcony, or other amenity space. Pivot features height adjustable articulating feet for stability on nearly any surface.

MATERIALS

Fluid Concrete Technology* surround.

*Concrete is a natural material. Each piece is hand made. Pieces are similar, but no two pieces are identical in color or appearance.

MODEL OPTIONS

Color	SKU
Natural	BJF.2.S.PVT.NA
Graphite	BJF.2.S.PVT.GH
Bone	BJF.2.S.PVT.BO

COMPATIBLE MODELS

Model	SKU
Equinox	BJF.5.EQU
Flo	BJF.5.FLO
Kove	BJF.5.KOV
Solstice	BJF.5.SOL
Urth	BJF.2.UTH

OPTIONAL ACCESSORIES

Accessory	SKU
Outdoor Cover	BJF.1.C.PVT

Pivot



A highly desired accessory to an outdoor fireplace, these tempered glass fire screens feature polycarbonate connectors which disappear once in place. While completely optional, glass screens stabilize the flame in windy conditions and provide an added layer of safety, peace of mind and comfort.

MATERIALS

Tempered glass and polycarbonate connectors. (Not applicable for Flo).

MODEL OPTIONS

Model	Fits	SKU
R650 [26"]	Equinox Solstice Kove	BLD.1.A.G.R650
L1080 [43"]	Flo	ESF.5.A.G.L1080

DIMENSIONS

Model	L	W	H
R650	26" 650mm	26" 650mm	5.9" 150mm
L1080	43" 1080mm	13" 340mm	10" 250mm

S
Z
E
E
R
O
S



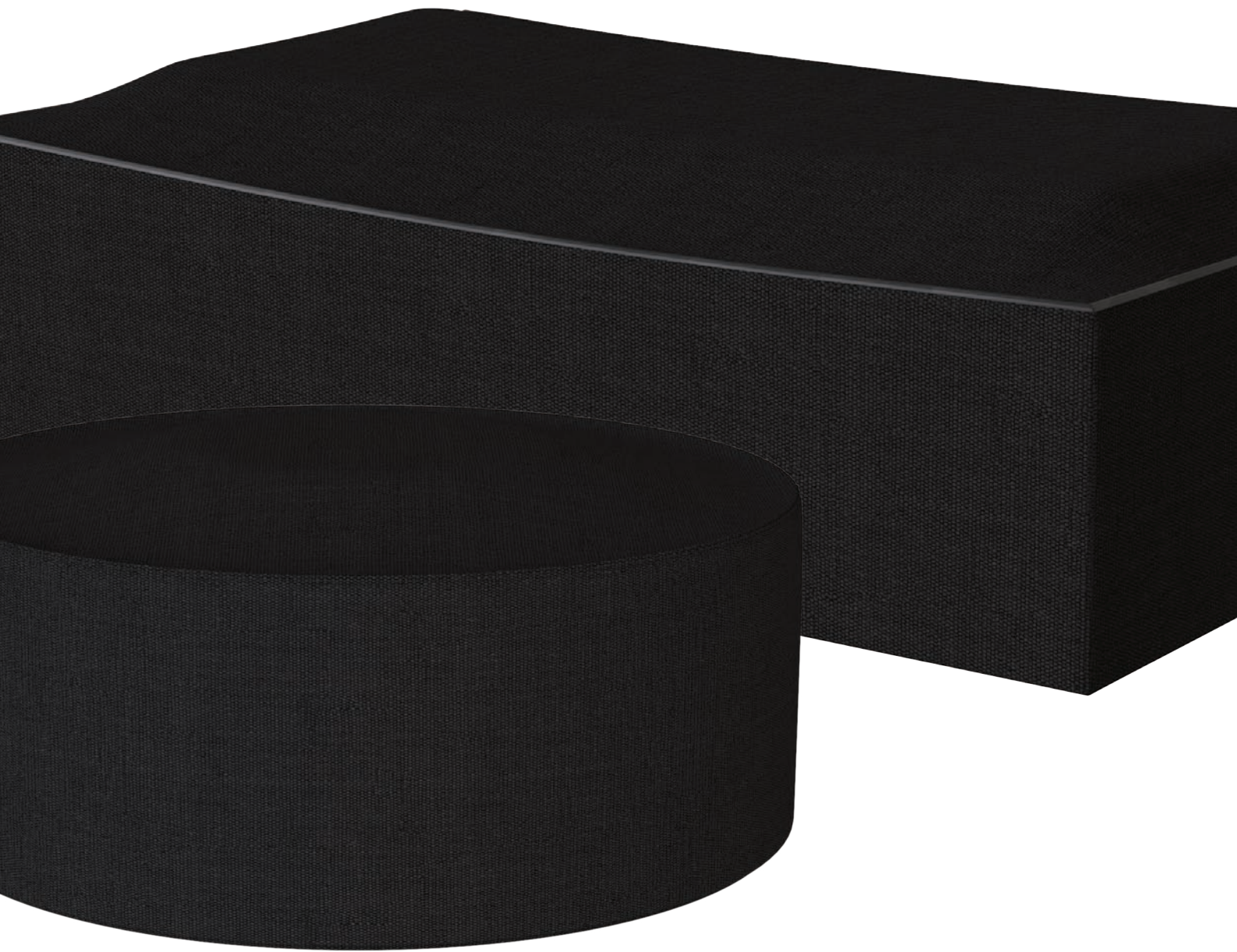

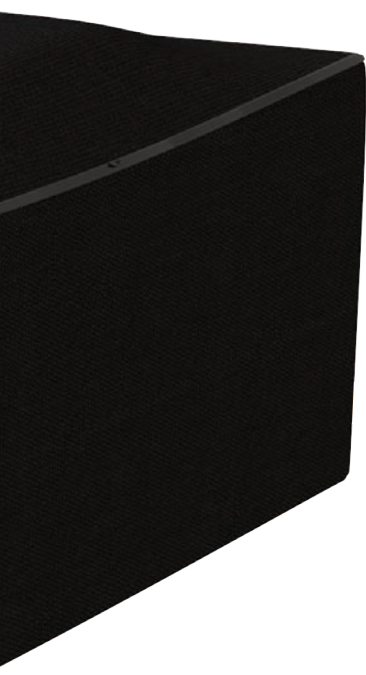

The outdoor cover/bag is made from a durable SANO-TEX fabric that resists mold, mildew, fading, UV rays, water, and extreme weather. Use as a protective cover in mild weather and as a storage bag in extreme weather

MATERIALS

Durable SANO-TEX fabric (100% solution-dyed polyester) with hand stitched brand identifier.

MODEL OPTIONS

To fit model	SKU
Equinox / Flo	BJF.5.WB.EQU/FLO
Hideout	BJF.5.WB.HDT
Solstice	BJF.5.WB.SOL
Kove	BJF.5.WB.KOV
Pivot	BJF.5.WB.PVT
Urth	BJF.5.WB.UTH

COVERS

We understand personal preferences when it comes to design and technology - that's why we've created a collection of fires that offer unprecedented choice. Inspired by Brown Jordan's legacy of quality and craftsmanship, Brown Jordan Fires are designed and manufactured with customer satisfaction at their core.

LEARN MORE

UNPRECEDENTED CHOICE

Brown Jordan Fires offer the freedom to choose the system that's right for you and your project.

Choose between plumbed natural gas, readily available propane, or our eco-friendly bioethanol fuel system. We make it easy for you to achieve exactly what you want, for exactly where you want it.

NATURAL GAS

Our Natural Gas (NG) systems provide not only the lowest cost of operation, they require no refuelling of any type, ever. Offering a high heat output and the flexibility to adjust the height of the flame as you desire, our Natural Gas burners feature a push button ignition and are UL/ULC Listed.

LIQUID PROPANE

Fueled by readily available propane, our LP solutions feature up to 65,000 BTUs of heat output while requiring no costs for installation. Our LP burners are UL/ULC Listed, include a battery powered push button ignition and offer the flexibility to relocate your fire feature as needed.

e-NRG BIOETHANOL

The most eco-friendly of our options, our UL Listed ethanol technology offers ultimate flexibility. Whether setting up for indoor or outdoor use, our ethanol fires are installed and operating in a matter of minutes. Completely self contained, ethanol provides the freedom to relocate your fire as desired without any limitations.

INSTALLATION

Approved Use	Outdoor Only	Outdoor Only	Indoor or Outdoor
UL/ULC Listed	UL/ULC	UL/ULC	UL
Can Be Relocated		•	•
Installation & Setup	Req. Certified Plumber	Easy	Easiest
Electrical Required	None	None	None

OPERATION

Heat Output (BTUs)	65,000	65,000	20,000
Burn Time	Unlimited	8 - 20 Hrs / Tank	8 - 13 Hrs / Fill
Operating Costs	\$0.20 - \$0.50 / Hour	\$1.50 - \$2.50 / Hour	\$1.50 - \$3.50 / Hour
Adjustable Flame / Heat	•	•	
Fuel Source	Permanent Connection	External Tank	Self Contained Burner
Fuel Availability	Plumbed	Readily Available	Delivered to your door
Green / Eco-Friendly			•

LP / NG Burners

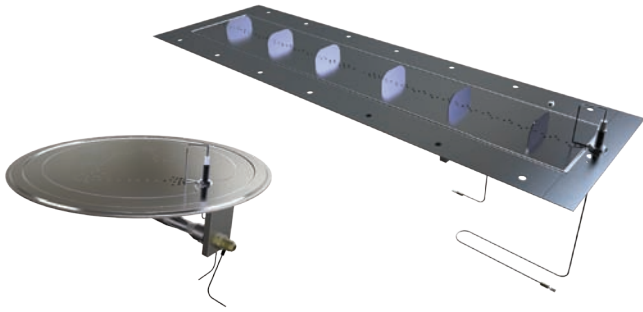

Featuring up to 65,000 BTU's of heat output, our Natural Gas (NG) and Propane (LP) Burners will warm even the coolest of evenings. Easy to assemble and even easier to maintain, our NG/LP burners are UL/ULC Listed, made from 304 Stainless Steel and feature baffles for flame stability.

Our unique burner port design ensures a superior flame pattern and experience each and every use. Gas burners ship ready for use as Propane and can easily be converted to Natural Gas using the included conversion kit.

Push Button Ignition

Operating our NG and LP Burners is a breeze thanks to our easy to use, battery powered push button ignition.

Flame Stability

Linear burners feature vertical baffles keeping your flame stable and consistent no matter the conditions.

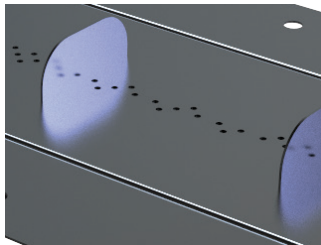

Temperature Control

Adjusting flame height and temperature is simple - turn the knob on the control panel to change your temperature. For added safety, use the included key rather than knob and remove as needed.

Superior Flame Pattern

Considered design ensures you experience the most robust and stable flame pattern with a 360° viewing angle.

Ethanol Burners



Fueled by clean burning e-NRG Bioethanol, our UL Listed EcoSmart Fire round burners and linear burner offer nothing short of a premium indoor or outdoor fire experience. Featuring an industry-leading 10-12 hours of burn per fill, nothing beats having your clean, renewable fuel delivered directly to your door!

Free of any hard line connections, an ethanol fired fireplace is not only free of any soot, smoke or ash, it is extremely easy to relocate. Manufactured from 304 stainless steel, all burners ship inclusive of accessories ensuring seamless operation at all times.

Included Operating Accessories

A Jerry Can, Lighting Rod, Lighter and Operations Manual are included with each burner. When ordering from the USA, an e-NRG bottle adapter and can of butane is also included.



Peak Performance

Completely self contained, each burner is engineered for industry leading burn times, stable flame pattern and longevity indoors or out.

Safety First

Whether it's the safe shut-off system, dedicated filling point, safety markings or volume guides, our bioethanol burners lead the way in safety.



Maintenance Free

e-NRG Bioethanol burns completely clean, leaving no soot or ash so maintenance is simple. They're also dishwasher safe in the event your burner requires a deep cleaning.

QUALITY MATERIALS

Brown Jordan Fires' commitment to offering a premium experience extends all the way down to the smallest features, material selection and included accessories.

Fluid Concrete Technology



Brown Jordan Fires' features are synonymous with quality, substance and enduring style and now those same qualities can be applied to our extensive concrete collection.

Incredibly strong yet relatively lightweight, Brown Jordan Fires concrete products incorporate revolutionary Fluid™ Concrete Technology. Fluid features a stain and impact-resistant barrier that protects the concrete from environmental weathering – even under extreme conditions and long UV exposure.

Fluid's customized curing process allows each Brown Jordan Fire piece to rest and set in quality controlled conditions, producing a consistently beautiful indoor and outdoor collection of designer concrete that last longer than traditional composites.

Concrete is a natural material and therefore each and every model will be unique in appearance.

After a concrete surface is polished there are a variety of visual differences that may be seen including water marks, trowel marks, marbling, mottled effects and random spotting etc. We cannot predict where the effects will show or what they will be – it is part of the beauty of concrete.

Concrete is a natural material. Each piece is hand made. Pieces are similar, but no 2 pieces are identical in color or appearance.

Tempered Glass

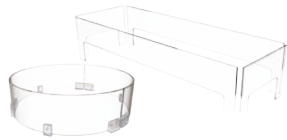

Tempered glass is stronger than normal glass and provides added protection. Tempered glass is ideal in windy environments.

Polycarbonate Connectors



Wear and impact resistant, our polycarbonate glass holders are not only the perfect material to stand up to harsh outdoor weather and high temperatures of our fires, they're easy on the eye thanks to the semi-translucent bead-blasted finish that won't yellow over time. (Not applicable for Flo Fire screen)

Charcoal Glass



The charcoal glass included with all Brown Jordan Fires' models is made from high quality tempered glass and has been designed to withstand harsh weather and temperatures of up to 1300°F/700°C without ever cracking, or losing its color or shape. Charcoal glass does not emit any toxic fumes, smoke, or ash so it is extremely easy to maintain and clean.

Articulating Feet



Made from 304 Stainless Steel with Nylon pad, these indispensable feet not only articulate 360° but are height adjustable up to 1" (25mm), keeping your Brown Jordan Fire balanced and stable no matter the surface.

PU Coated Oxford Fabric



A coating of breathable polyurethane over oxford fabric ensures seamless protection from outdoor elements. Finished in a Teflon coating for stain resistance and easy maintenance, PU Coated Oxford Fabric is UV resistant and waterproof.

Common Questions

How do I light my Brown Jordan Fire?

The instruction manual that accompanies your purchase includes a step by step lighting procedure to make sure you're able to light your Brown Jordan Fire safely and correctly. We also have an informative video on our website that covers the lighting and extinguishing of your Brown Jordan Fire.

Does my Brown Jordan Fire require any assembly?

Most Brown Jordan Fires require only minor assembly. More often than not, your fire can be ready to operate in less than 30 minutes by following the included assembly and operations manual. If choosing Natural Gas, a licensed plumber will be required to complete the installation to the permanent gas line.

How do I clean my fire?

Brown Jordan Fires are made from durable Fluid Concrete Technology and Stainless Steel and can be cleaned using a simple spray surface cleaner and sponge. Avoid using harsh abrasives or scrubbing tools as they can scratch the products' surface. Just wipe to get your Brown Jordan Fire looking like new. Outdoor covers are also available to help you save on elbow grease and keep your fire looking its best.

Are Brown Jordan Fires weather resistant?

All products are made to withstand the elements. For added protection, outdoor covers are available to keep your Brown Jordan Fire in tip top shape for years to come.

How do I maintain my Brown Jordan Fire?

This unit has been sealed with Meguiar's Deep Crystal Carnauba Wax to seal and protect it. We recommend you reseal it every 6 months for maintenance.

Meguiar's Deep Crystal Carnauba Wax is available online at Mequiars.com, Amazon.com, Walmart.com, Target.com and in store at Walmart, Target, Pep Boys, Auto Zone and many fine retailers.

Do Brown Jordan Fires give off heat?

They most certainly do. Our firepits, fire tables and tall tables provide warmth and ambience of up to 55,000 BTUs / hour when operating on NG or LP.

Do you offer on site consultations or design services?

We do not currently provide on site consultations but our network of experienced authorized retailers and support team are available to speak with you over the phone, via email or in store.

Are glass screens available?

Many Brown Jordan Fires have glass screens available as optional accessories. Please check the model specifications for your desired fire to see if a glass screen is available as an optional accessory.

Do you offer custom designs or colors?

Not at this time. The extensive Brown Jordan Fires collection is available in the standard colors shown on the model specifications page.

My ground surface is uneven, will my fireplace be stable?

Brown Jordan Fires feature height adjustable articulating feet, which ensures your fireplace or accessory is stable and balanced.

How do I convert the gas burner from LP to NG?

Each burner ships as LP, but the component required to convert to NG is included with each burner. See the Installation instructions supplied with the burner for complete details on converting to NG.

Can I change from ethanol to NG/LP or vice versa?

While this is not something you would want to do with any frequency, yes the burner can be changed if you decide you would like to change from NG/LP to ethanol or from ethanol to NG/LP.

About e-NRG Bioethanol



e-NRG bioethanol is a high quality, clean burning fuel specifically formulated for use in liquid ethanol fueled ventless fireplaces.

Bioethanol burns clean, emitting only heat, steam & carbon dioxide.

For your safety, e-NRG bioethanol bottles are fitted with a flame arrester for maximum safety. Always follow the instructions on the bottle label.

Why e-NRG



Best Flame



Clean Burning



Lowest Odor



Longest Burn



Order Online



Fast Delivery

How do I order e-NRG?

Available in a range of economical sizes, most e-NRG deliveries are completed within three business days or less.

NORTH AMERICA

Visit e-nrg.com

Phone **(888) 670 ENRG**

AUSTRALIA

Visit e-nrg.com.au

Phone **1300 003 NRG**

Warranty

Brown Jordan Fires are designed and manufactured by MAD Design Group.

Brown Jordan Fires are covered by a transferable limited warranty and a solid service and support network should you need it. Many aspects of Brown Jordan Fires are hand-produced, hand-finished and use natural materials, which makes them subject to minor variations in finish and size. All pieces will mature and age over the course of time through natural processes associated with use, heat and flame. These changes are an essential part of the dynamic of the piece. MAD Design Group reserves the right to make minor amendments without prior notice.

Length of Warranty

12 MONTH WARRANTY FROM DATE OF PURCHASE ON STAINLESS STEEL PARTS INCLUDING RAW, LISHED AND POWDER COATED, ON MILD STEEL INCLUDING POWDER COATED AND CHROME PLATED, CONCRETE, GLASS, LEATHER, FABRIC AND MDF (PAINTED OR RENDERED).

Chips and scratches are not covered by warranty. Natural variation in color, texture and porosity may occur with Fluid Concrete Technology products and are considered inherent and valued qualities of the material. Non-structural hairline cracks are possible and shall not be considered a manufacturing defect.

COLORS

Now available across all Brown Jordan Fires and Accessories, our newly expanded range of finish options adds depth, freshness and flexibility to an already vibrant offering.

Natural

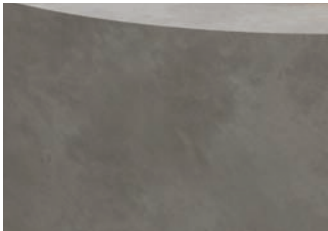

Our most versatile shade, Natural is an organic concrete finish that seamlessly integrates into contemporary or traditional spaces.

Graphite



Sleek and modern, Graphite demands attention. Familiar yet fresh, Graphite compliments a range of alfresco spaces.

Bone

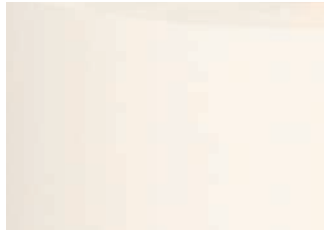

A trendsetting finish with a clean and crisp texture. Bone is inspired by coastal tones and peaceful spaces.





CONTACT

Contact Details

NORTH AMERICA

Visit:

brownjordanfires.com

Phone:

+1 (888) 488.4447

AUSTRALIA

Visit:

brownjordanfires.com.au

Phone:

+61 2 9997 3050

For customer enquiries or requests outside of the regions listed above please contact our North American office.

Brown Jordan is a trademark of Brown Jordan International, Inc. and is used under license to EcoSmart Inc.

Reproduction of this catalog in any manner, in any language, in whole or in part without prior written permission is prohibited. MAD Design Group reserves the right to correct any errors or misprints. We also reserve the right to alter information without notification. The information provided herein is believed to be correct but is not guaranteed. V1020

International Patent Pending
Trademarks Pending
All Designs Registered

BROWN
JORDAN
FIRES
.COM

BROWN JORDAN
FIRES